

 **ALULIN by
Dr. TRETTER AG**



TRAPEZGEWINDETRIEBE TRAPEZOIDAL SCREW DRIVES



VIELSEITIG EINSETZBAR
VERSATILE IN USE



LANGLEBIG
LONG-LASTING



HERGESTELLT IN DE
MADE IN GERMANY

01

Technik Technical Data

Produktbeschreibung Product description	4
Endenbearbeitung End Machining	5
Lagereinheiten Bearing Units	5

02

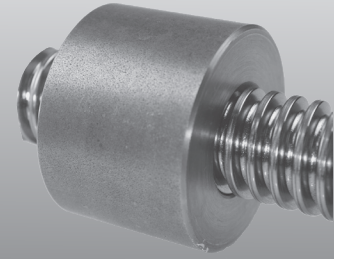

Rundmuttern (Rohlinge) Round Nuts (blanks)

Stahl/Niro-Rundmutter - kurz Steel/Stainless Round Nut - short	6
Kunststoff-Rundmutter - lang Plastic Round Nut - long	7
Stahl-Rundmutter - lang Steel Round Nut - long	8
Rotguss-Rundmutter - lang Red Brass Round Nut - long	9

03

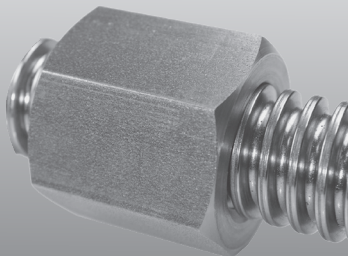

Sechskantmuttern (Rohlinge) Hexagon Nuts (blanks)

Stahl/Niro-Sechskantmutter Steel/Stainless Hexagon Nut	10
Messing-Sechskantmutter Brass Hexagon Nut	11

04

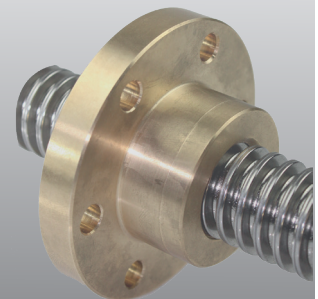

Flanschmuttern Flange Nuts

Rotguss-Flanschmutter - Rohling Red Brass Flange Nut - blank	12
Einbaufertige Rotguss-Flanschmutter Red Brass Flange Nut finished	13
Einstellbare Rotguss-Flanschmutter Red Brass Flange Nut adjustable	15

05

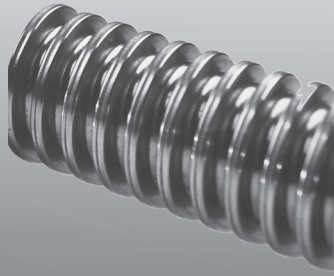

Trapezgewindespindeln Trapezoidal Screws

Trapezgewindespindeln Trapezoidal Screws	16
Niro-Trapezgewindespindeln Stainless Trapezoidal Screws	18

01

02

03

04

05

© Copyright
Nachdruck, auch auszugsweise, ist nur mit unserer Genehmigung gestattet.
Alle Angaben in diesem Katalog wurden sorgfältig erstellt und geprüft. Trotzdem können wir für unvollständige oder fehlerhafte Angaben keine Haftung übernehmen. Frühere Ausgaben dieses Kataloges treten außer Kraft. Änderungen, welche dem technischen Fortschritt dienen oder auf Normänderungen beruhen, behalten wir uns vor.

© Copyright
Reprinting, including extracts, only permitted with our approval.
All information in this catalogue has been carefully compiled and checked. However, we accept no liability for incomplete or incorrect information. Previous editions of this catalogue are no longer valid. We reserve the right to make changes to reflect technical advancements or comply with changes in industrial standards.



Produktbeschreibung

Trapezgewindetriebe sind kostengünstige Maschinenelemente, die eine rotative Bewegung in eine lineare Vorschubbewegung umwandeln.

Die Vorteile gegenüber den aufwändigeren Kugelgewindetrieben sind neben dem Preis die Selbsthemmung bei eingängigen Trapezspindeln (Steigungswinkel < 4°) für Hub- und Spannvorrichtungen. Desweiteren ist eine hohe Verfügbarkeit in Niro bei hoher Beständigkeit gegenüber Salzwasser und Säuren vorteilhaft.

Zu beachten ist allerdings eine höhere Reibung und damit Erwärmung und das bei Einzelmuttern vorhandene Spiel. Durch das trapezförmige Profil mit einem Flankenwinkel von 15° nach DIN 103 können höhere Kräfte bei geringerer Reibung gegenüber einem DIN ISO Regelgewinde übertragen werden.

Product description

Trapezoidal Screw Drives are low cost machine elements for conversion of a rotary movement into a linear movement. The advantages compared to the more complex Ball Screws are in addition to the price also the self-locking capacity for single thread Trapezoidal Screws (lead angle < 4°) used in lifting and clamping devices. Moreover the high availability of stainless steel with a high resistance to acids and salt water is advantageous.

However it should be noted the higher friction and therefore the warming of the nut and the backlash for single nuts. Due to trapezoidal shape with a flank angle of 15° according to DIN 103, higher forces with less friction can be transmitted compared to a DIN ISO regular thread.

01

Produktübersicht

Product overview

Trapezgewindespindel
Trapezoidal Screw

- Stahl steel
- Niro stainless steel

Rundmutter
Round Nut

- Stahl steel
- Niro stainless steel
- Kunststoff plastic
- Rotguss red brass

Sechskantmutter
Hexagon Nut

- Stahl steel
- Niro stainless steel
- Messing brass

Flanschmutter
Flang Nut

- Rotguss - Rohling red brass - blank
- Rotguss einbaufertig red brass finished
- Rotguss einstellbar, spielarm
Red brass adjustable, low backlash

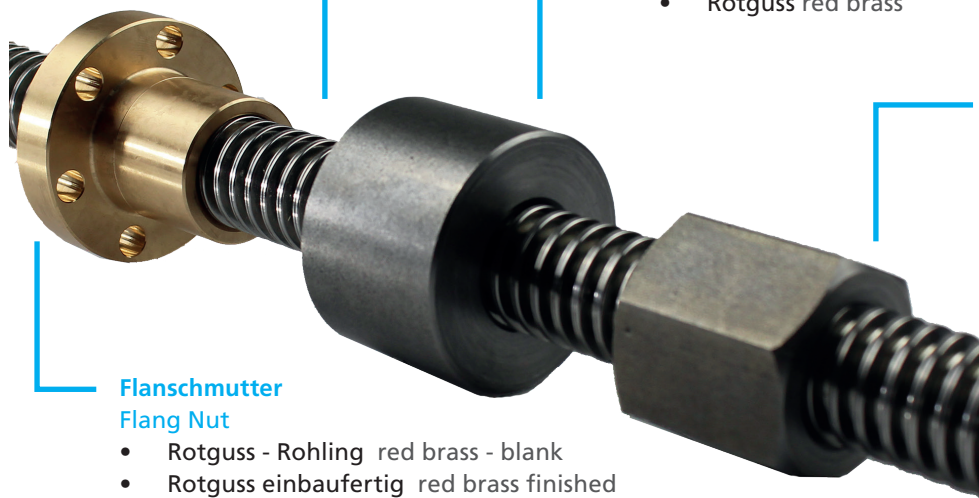

Unsere Trapezgewindespindeln werden gerollt und bestehen aus Stahl oder korrosionsbeständigem V2A. Durch die spanlose Formgebung und dem damit verbundenen ununterbrochenen Faserverlauf sind die mechanischen Eigenschaften wie Zugfestigkeit, Oberflächenhärte und -güte besser als bei gewirbelten Spindeln.

Our Trapezoidal Screws are rolled and are made of steel or corrosion resistant V2A stainless steel. Due to the chipless shaping and related uninterrupted grain structure, the mechanical characteristics such as tensile strength, surface hardness and finish are better compared to whirled screws.

Stahl- und Niro-Muttern eignen sich für Anwendungen mit geringer Geschwindigkeit wie Spannvorrichtungen und Handverstellungen. Sie neigen zum Kaltverschweißen bei höherer Last und müssen daher gut geschmiert werden.

Steel and stainless steel nuts are suitable for low speed applications like clamping devices and manual adjustment units. A proper lubrication is essential because they have an inclination for cold welding under higher load.



Rotguss- und Messingmuttern werden bei Bewegungsanwendungen mit kleineren bis mittleren Geschwindigkeiten und Einschalt Dauern unter 20% eingesetzt. Sie besitzen gute Notlaufeigenschaften und in Verbindung mit VA-Spindeln gute Korrosionsbeständigkeit.

Kunststoffmuttern aus PETP für Bewegungsanwendungen bei mäßigen Belastungen zeichnen sich durch geräuscharmen Lauf und sehr gute Notlaufeigenschaften aus. In den meisten Fällen ist eine Erstbefettung als Einlaufschmierung ausreichend.

Brass and red brass nuts are used for drive systems at low and medium speed and operating times under 20%. They have good dry running properties and a good corrosion resistance in combination with a stainless screw.

Plastic nuts of PETP for drive systems at moderate load are characterized by their low noise and their very good dry running properties. In most cases an initial run-in lubrication is sufficient.

Endenbearbeitung

Die Spindelenden bearbeiten wir entweder nach Kundenzeichnung oder abgestimmt auf unsere Lagereinheiten (siehe Katalog: „Zubehör Gewindetriebe“).

End Machining

We machine the screw ends either according to customers drawing or ready to fit for our own bearing units (see catalogue „Accessories for screw drives“).

Lagereinheiten

Wir bieten die passenden Lagereinheiten für Trapezgewindetriebe als Fest- oder Loslagereinheit, in Stehlagerausführung oder als Flanschlagereinheit. Die verschiedenen Ausführungen finden Sie in unserem Katalog (siehe Katalog: „Zubehör Gewindetriebe“).

Bearing Units

We provide bearing units suitable for Trapezoidal Screws as fixed or floating bearing units either as block or flanged type. You can find the different versions in our catalogue (see catalogue „Accessories for Screw Drives“).



Anwendungsbeispiele Example applications

Aufgrund Ihrer Selbsthemmung werden Trapezgewindespindeln häufig als Antriebselement für sämtliche Z-Achsen eingesetzt.

Typische Einsatzgebiete sind:
Verstelleinheiten, spielfreie Positioniersysteme, Spannmittel, Hubstationen und 3-D-Drucker

Trapezoidal Screw Drives are often used as drive section for many Z-axis due to their self-locking capacity.

Typical applications are:
adjusting units, positioning systems without backlash, clamping devices, lifting stations and 3D-printer.

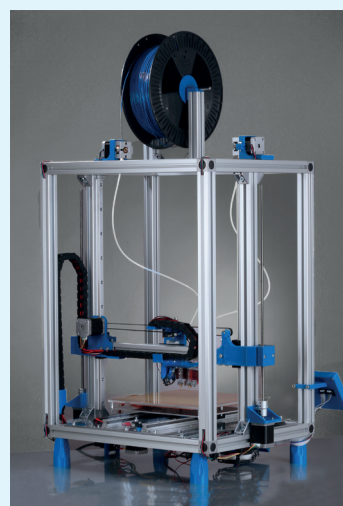

Für Spannvorgänge, Verstellbewegungen im Handbetrieb und als Befestigungsmutter geeignet. Kann im Lieferzustand eingebaut bzw. zur Weiterbearbeitung verwendet werden.

Suitable for clamping procedures, manual adjustment units and fixing nuts. Can be mounted in delivery state or used for further machining.



hoch belastbar
high load-bearing capacity

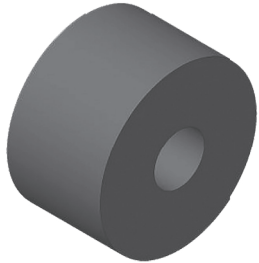

Stahl/Niro-Rundmutter - kurz - Typ QRMK Steel/Stainless Round Nut - short Typ QRMK



optional rostbeständig
Werkstoff 1.4305 [QRMK....R5/L5]
optional stainless steel
material 1.4305 [QRMK....R5/L5]

- Gewinde nach DIN ISO 103
- Werkstoff: 11SMnPb30, (1.0718)
- Zeichnung siehe Seite 7

- Thread according to DIN ISO 103
- Material: 11SMnPb30, (1.0718)
- Drawing see page 7

02

Bestellzeichen order references		Abmessungen dimensions [mm]		Gewicht weight
rechtsgängig right hand	linksgängig left hand	D	L	kg
QRMK 8x1,5 R1	QRMK 8x1,5 L1	22	15	0,04
QRMK 10x2 R1	QRMK 10x2 L1	22	15	0,04
QRMK 10x3 R1	QRMK 10x3 L1	22	15	0,04
QRMK 12x2 R1	QRMK 12x2 L1	26	18	0,06
QRMK 12x3 R1	QRMK 12x3 L1	26	18	0,06
QRMK 14x3 R1	QRMK 14x3 L1	30	21	0,09
QRMK 14x4 R1*	QRMK 14x4 L1	30	21	0,09
QRMK 16x2 R1	QRMK 16x2 L1	36	24	0,16
QRMK 16x4 R1	QRMK 16x4 L1	36	24	0,15
QRMK 18x4 R1	QRMK 18x4 L1	40	27	0,21
QRMK 20x2 R1	QRMK 20x2 L1	45	30	0,30
QRMK 20x4 R1	QRMK 20x4 L1	45	30	0,30
QRMK 22x5 R1	QRMK 22x5 L1	45	33	0,32
QRMK 24x5 R1	QRMK 24x5 L1	50	36	0,44
QRMK 26x5 R1	QRMK 26x5 L1	50	39	0,45
QRMK 28x5 R1	QRMK 28x5 L1	60	42	0,75
QRMK 30x6 R1	QRMK 30x6 L1	60	45	0,75
QRMK 32x6 R1	QRMK 32x6 L1	60	48	0,79
QRMK 36x6 R1	QRMK 36x6 L1	75	54	1,48
QRMK 40x7 R1	QRMK 40x7 L1	80	60	1,83
QRMK 50x8 R1*	QRMK 50x8 L1*	90	75	2,70
QRMK 60x9 R1*	QRMK 60x9 L1*	100	90	3,71



*Diese Größen sind nicht in Niro lieferbar.
*These sizes are not available in stainless steel.



Für geräuscharme Bewegungsantriebe. Mit gerollten Trapezgewindespindeln besonders gute Laufeigenschaft. Kann im Lieferzustand eingebaut bzw. zur Weiterbearbeitung verwendet werden.

For low noise drive systems. Together with Trapezoidal Screws best running properties. Can be mounted in delivery state or used for further machining.



Kunststoff-Rundmutter - lang - Typ QRM
Plastic Round Nut - long - type QRM

- Gewinde nach DIN ISO 103
- Werkstoff: PETP
- Thread according to DIN ISO 103
- Material: PETP

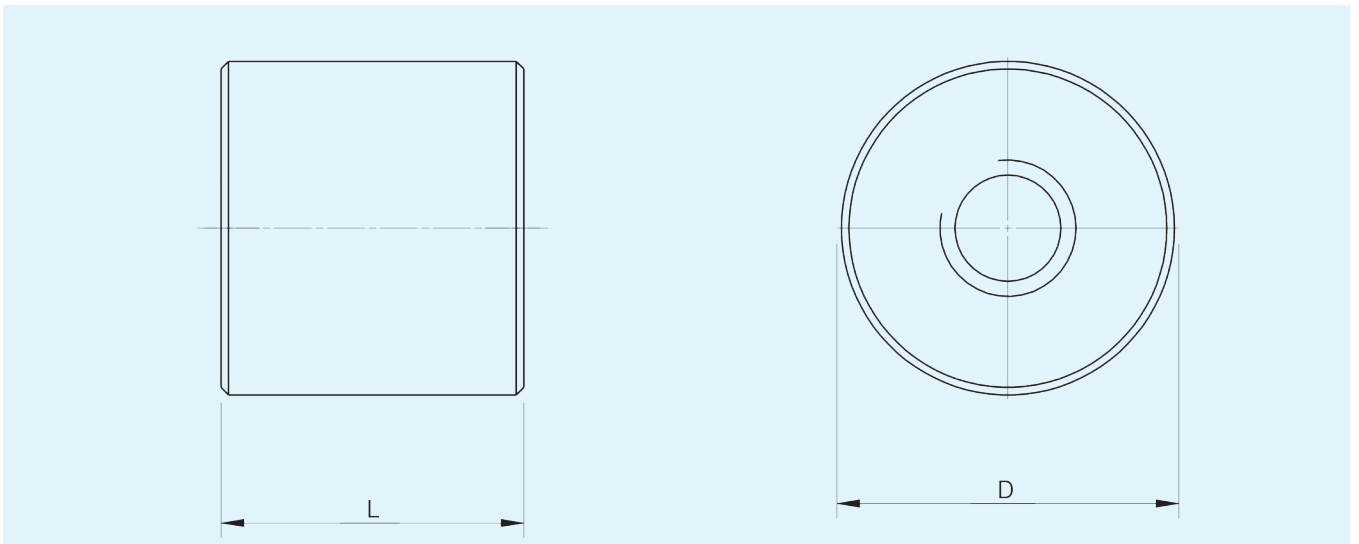

02

Bestellzeichen order references		Abmessungen dimensions [mm]		Gewicht weight
rechtsgängig right hand	linksgängig left hand	D	L	kg
QRM 12x3 R3	QRM 12x3 L3	26	24	0,01
QRM 12x6P3 R3		26	24	0,01
QRM 16x4 R3	QRM 16x4 L3	36	32	0,04
QRM 16x8P4 R3		36	32	0,04
QRM 20x4 R3	QRM 20x4 L3	45	40	0,07
QRM 20x8 R3		45	40	0,07
QRM 24x5 R3	QRM 24x5 L3	50	48	0,10
QRM 24x10P5 R3		50	48	0,10
QRM 30x6 R3	QRM 30x6 L3	60	60	0,18
QRM 30x12P6 R3		60	60	0,18
QRM 36x6 R3	QRM 36x6 L3	75	72	0,35
QRM 40x7 R3	QRM 40x7 L3	80	80	0,43



Unser Service steht Ihnen gerne telefonisch (+41 (0)52 670 06 10) oder per Email (info@tretter.ch) zur Verfügung.
 Our Service Department would be delighted to help you either by telephone (+41 (0)52 670 06 10) or e-mail (info@tretter.ch).



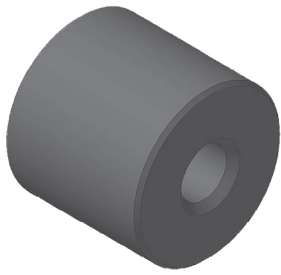

Stahl-Rundmutter - lang - Typ QRM
Steel Round Nut - long - type QRM

- Gewinde nach DIN ISO 103
- Werkstoff: 11SMnPb30, (1.0718)

- Thread according to DIN ISO 103
- Material: 11SMnPb30, (1.0718)

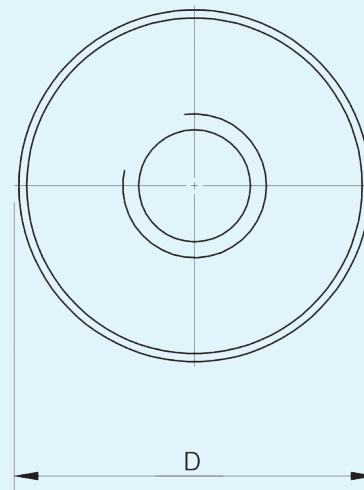
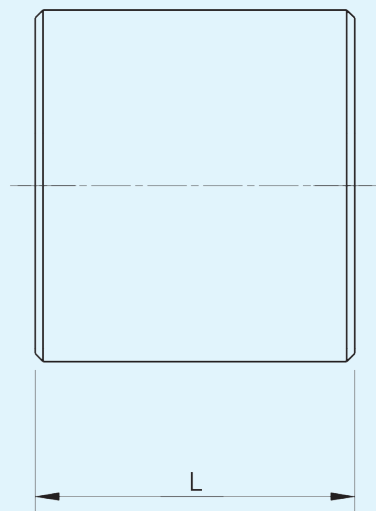

02

Bestellzeichen order references		Abmessungen dimensions [mm]		Gewicht weight
rechtsgängig right hand	linksgängig left hand	D	L	kg
QRM 14x3 R1	QRM 14x3 L1	30	28	0,12
QRM 16x4 R1	QRM 16x4 L1	36	32	0,21
QRM 18x4 R1	QRM 18x4 L1	40	36	0,30
QRM 20x4 R1	QRM 20x4 L1	45	40	0,41
QRM 22x5 R1	QRM 22x5 L1	45	44	0,43
QRM 24x5 R1	QRM 24x5 L1	50	48	0,58
QRM 28x5 R1	QRM 28x5 L1	60	56	1,00
QRM 30x6 R1	QRM 30x6 L1	60	60	1,03
QRM 32x6 R1	QRM 32x6 L1	60	64	1,05
QRM 36x6 R1	QRM 36x6 L1	75	72	2,00
QRM 40x7 R1	QRM 40x7 L1	80	80	2,44
QRM 50x R1	QRM 50x8 L1	90	100	3,10
QRM 60x9 R1	QRM 60x9 L1	100	120	5,00



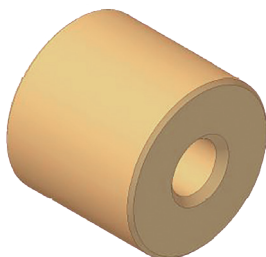

Rotguss-Rundmutter - lang - Typ QRM
Red Brass Round Nut - long - type QRM

- Gewinde nach DIN ISO 103
- Werkstoff: CuSn 7Zn (Rg7), (2.1090)
- Zeichnung siehe Seite 8
- Thread according to DIN ISO 103
- Material: CuSn (Rg7), (2.1090)
- Drawing see page 8

Bestellzeichen order references		Abmessungen dimensions [mm]		Gewicht weight
rechtsgängig right hand	linksgängig left hand	D	L	kg
QRM 5X1,5 R7	QRM 5X1,5 L7	12	8	0,01
QRM 5x3P1,5 R7	-	12	8	0,01
QRM 8X1,5 R7	QRM 8X1,5 L7	22	20	0,06
QRM 10X2 R7	QRM 10X2 L7	22	20	0,06
QRM 10x3 R7	QRM 10x3 L7	22	20	0,06
QRM 12X2 R7	QRM 12X2 L7	26	24	0,09
QRM 12x3 R7	QRM 12x3 L7	26	24	0,09
QRM 12X6P3 R7	-	26	24	0,09
QRM 14x3 R7	QRM 14x3 L7	30	28	0,14
QRM 14x4 R7	QRM 14x4 L7	30	28	0,14
QRM 16x2 R7	QRM 16x2 L7	36	32	0,23
QRM 16x4 R7	QRM 16x4 L7	36	32	0,24
QRM 16x8P4 R7	-	36	32	0,24
QRM 18x4 R7	QRM 18x4 L7	40	36	0,33
QRM 20x2 R7	QRM 20x2 L7	45	40	0,47
QRM 20x4 R7	QRM 20x4 L7	45	40	0,47
QRM 20x8P4 R7	-	45	40	0,47
QRM 20x16P4 R7	-	45	40	0,47
QRM 22x5 R7	QRM 22x5 L7	45	40	0,45
QRM 22x24P4 R7	-	45	40	0,45
QRM 24x5 R7	QRM 24x5 L7	50	48	0,68
QRM 24x10P5 R7	-	50	48	0,68
QRM 26x5 R7	QRM 26x5 L7	50	48	0,65
QRM 28x5 R7	QRM 28x5 L7	60	60	1,25
QRM 30x4 R7	QRM 30x4 L7	60	60	1,2
QRM 30x6 R7	QRM 30x6 L7	60	60	1,2
QRM 30x12P6 R7	-	60	60	1,2
QRM 32x6 R7	QRM 32x6 L7	60	60	1,15
QRM 36x6 R7	QRM 36x6 L7	75	72	2,25
QRM 40x7 R7	QRM 40x7 L7	80	80	2,8
QRM 40x14P7 R7	-	80	80	2,8
QRM 50X8 R7	QRM 50X8 L7	90	100	4,15
QRM 60X9 R7	QRM 60X9 L7	100	120	5,70



Für Spannvorgänge, Verstellbewegungen im Handbetrieb und als Befestigungsmutter geeignet. Kann im Lieferzustand eingebaut bzw. zur Weiterbearbeitung verwendet werden.

Suitable for clamping procedures, manual adjustment units and fixing nuts. Can be mounted in delivery state or used for further machining.

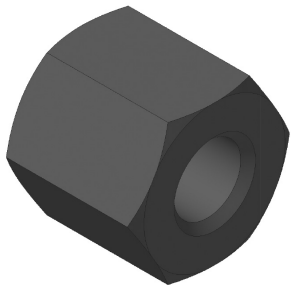

Stahl/Niro-Sechskantmutter - Typ QKM Steel/Stainless Hexagon Nut - type QKM



optional rostbeständig
Werkstoff 1.4305 [QKM....R5/L5]
optional stainless steel
material 1.4305 [QKM....R5/L5]

- Gewinde nach DIN ISO 103
- Werkstoff: 11SMnPb30, (1.0718)
- Zeichnung siehe Seite 11
- Thread according to DIN ISO 103
- Material: 11SMnPb30, (1.0718)
- Drawing see page 11

Bestellzeichen order references		Abmessungen dimensions [mm]		Gewicht weight
rechtsgängig right hand	linksgängig left hand	SW	L	kg
QKM 8x1,5 R1	QKM 8x1,5 L1	17	15	0,02
QKM 10x2 R1	QKM 10x2 L1	17	15	0,02
QKM 10x3 R1	QKM 10x3 L1	17	15	0,02
QKM 12x2 R1	QKM 12x2 L1	19	18	0,03
QKM 12x3 R1	QKM 12x3 L1	19	18	0,03
QKM 14x3 R1	QKM 14x3 L1	22	21	0,05
QKM 14x4 R1*	QKM 14x4 L1	22	21	0,05
QKM 16x2 R1	QKM 16x2 L1	27	24	0,08
QKM 16x4 R1	QKM 16x4 L1	27	24	0,08
QKM 18x4 R1	QKM 18x4 L1	27	27	0,08
QKM 20x2 R1	QKM 20x2 L1	30	30	0,12
QKM 20x4 R1	QKM 20x4 L1	30	30	0,12
QKM 22x5 R1	QKM 22x5 L1	30	33	0,12
QKM 24x5 R1	QKM 24x5 L1	36	36	0,20
QKM 26x5 R1	QKM 26x5 L1	36	39	0,20
QKM 28x5 R1	QKM 28x5 L1	41	42	0,29
QKM 30x6 R1	QKM 30x6 L1	46	45	0,42
QKM 32x6 R1	QKM 32x6 L1	46	48	0,42
QKM 36x6 R1	QKM 36x6 L1	55	54	0,71
QKM 40x7 R1	QKM 40x7 L1	65	60	1,20
QKM 50x8 R1*	QKM 50x8 L1*	75	75	1,80
QKM 60x9 R1*	QKM 60x9 L1*	90	90	3,10

i *Diese Größen sind nicht in Niro lieferbar.
*These sizes are not available in stainless steel.



Messing-Sechskantmutter - Typ QKM Brass Hexagon Nut - type QKM

- Gewinde nach DIN ISO 103
- Werkstoff: CuZn39Pb3, (CW614N)
- Thread according to DIN ISO 103
- Material: CuZn39Pb3, (CW614N)

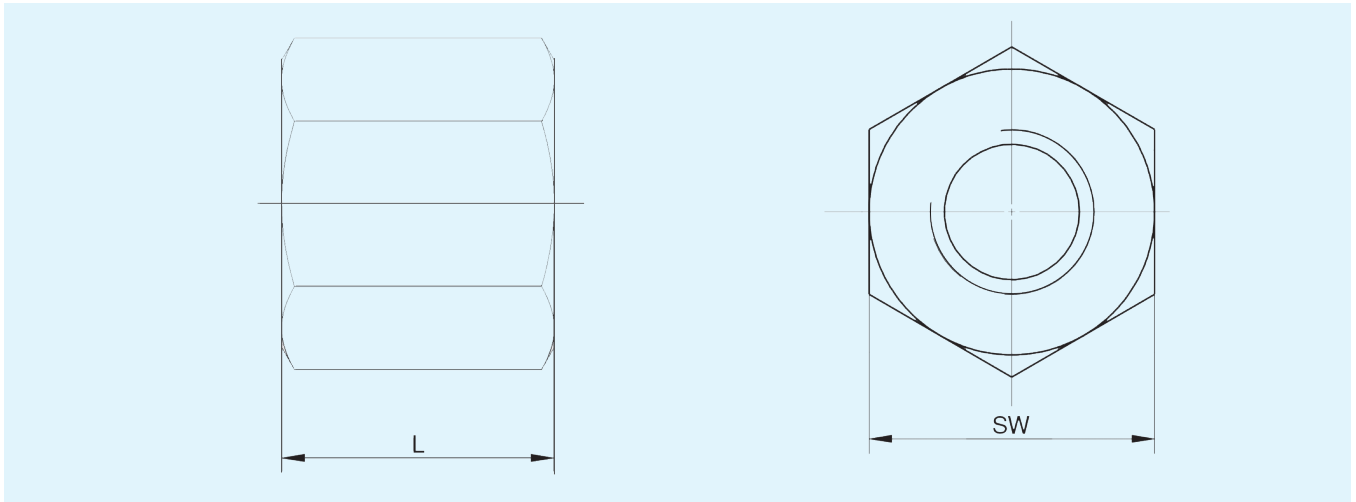

Bestellzeichen order references		Abmessungen dimensions [mm]		Gewicht weight
rechtsgängig right hand	linksgängig left hand	SW	L	kg
QKM 5x1,5 R6	QKM 5x1,5 L6	10	8	0,005
QKM 5X3P1,5 R6	---	10	8	0,005
QKM 8x1,5 R6	QKM 8x1,5 L6	17	15	0,02
QKM 10x2 R6	QKM 10x2 L6	17	15	0,02
QKM 10x3 R6	QKM 10x3 L6	17	15	0,02
QKM 12x2 R6	QKM 12x2 L6	19	18	0,02
QKM 12x3 R6	QKM 12x3 L6	19	18	0,03
QKM 14x3 R6	QKM 14x3 L6	22	21	0,05
QKM 14x4 R6	QKM 14x4 L6	22	21	0,05
QKM 16x2 R6	QKM 16x2 L6	27	24	0,08
QKM 16x4 R6	QKM 16x4 L6	27	24	0,08
QKM 18x4 R6	QKM 18x4 L6	27	27	0,08
QKM 20x2 R6	QKM 20x2 L6	30	30	0,12
QKM 20x4 R6	QKM 20x4 L6	30	30	0,12
QKM 22x5 R6	QKM 22x5 L6	30	33	0,12
QKM 24x5 R6	QKM 24x5 L6	36	36	0,20
QKM 26x5 R6	QKM 26x5 L6	36	39	0,20
QKM 28x5 R6	QKM 28x5 L6	41	42	0,29
QKM 30x6 R6	QKM 30x6 L6	46	45	0,42
QKM 32x6 R6	QKM 32x6 L6	46	48	0,42
QKM 36x6 R6	QKM 36x6 L6	55	54	0,72
QKM 40x7 R6	QKM 40x7 L6	65	60	1,20



Für Bewegungsantriebe kleiner und mittlerer Geschwindigkeit. Kann zur Weiterbearbeitung verwendet werden.

For drive systems at low and medium speed. Can be mounted in delivery state or used for further machining.

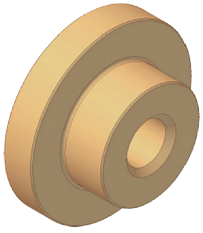

Rotguss-Flanschmutter - Rohling - QFMR

Red Brass Flange Nut - blank - QFMR

- Gewinde nach DIN ISO 103
- Werkstoff: CuSn 7Zn (Rg7), (2.1090)

- Thread according to DIN ISO 103
- Material: CuSn (Rg7), (2.1090)

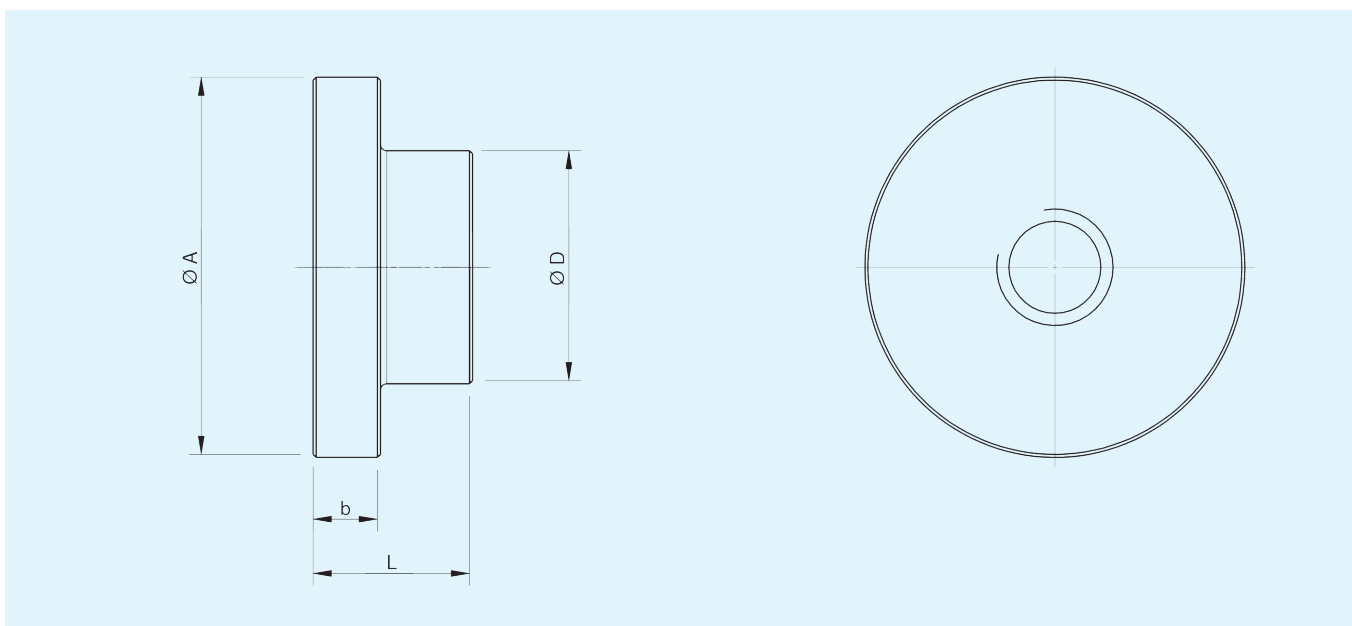

Bestellzeichen order references		Abmessungen dimensions [mm]				Gewicht weight
rechtsgängig right hand	linksgängig left hand	A	D	L	b	kg
QFMR 10x3 R7	---	35	20	15	6	0,07
QFMR 12x3 R7	QFMR 12x3 L7	42	24	20	7	0,12
QFMR 16x4 R7	QFMR 16x4 L7	52	30	24	10	0,24
QFMR 20x4 R7	QFMR 20x4 L7	62	38	26	11	0,36
QFMR 22x5 R7	QFMR 22x5 L7	77	50	33	13	0,79
QFMR 24x5 R7	QFMR 24x5 L7	77	50	33	13	0,77
QFMR 26x5 R7	QFMR 26x5 L7	77	50	33	13	0,75
QFMR 28x5 R7	QFMR 28x5 L7	90	58	48	15	1,40
QFMR 30x6 R7	QFMR 30x6 L7	90	58	48	15	1,36
QFMR 32x6 R7	QFMR 32x6 L7	115	80	60	20	3,25
QFMR 36x6 R7	QFMR 36x6 L7	115	80	60	20	3,20
QFMR 40x7 R7	QFMR 40x7 L7	140	80	65	20	4,12
QFMR 50x8 R7	QFMR 50x8 L7	170	90	70	20	5,90



Die QFM ist ein Produkt, das einbaufertig bearbeitet ist. Kann ohne weitere Bearbeitung konstruktiv eingeplant und sofort eingebaut werden. Sehr gut für Bewegungsantriebe geeignet.

The QFM Flange Nut is prefinished and can be mounted without further machining. It is perfectly suited for drive systems.

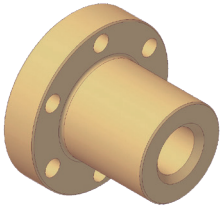

Einbaufertige Rotguss-Flanschmutter - lang - Typ QFM Red Brass Flange Nut finished - long - type QFM

- Gewinde nach DIN ISO 103
- Werkstoff: CuSn 7Zn (Rg7), (2.1090)

- Thread according to DIN ISO 103
- Material: CuSn (Rg7), (2.1090)

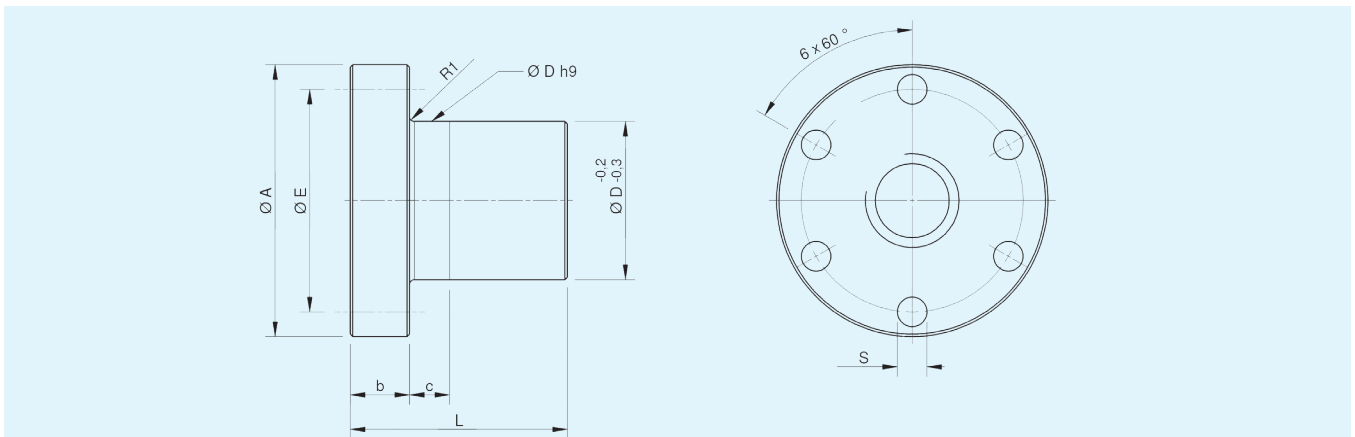

Bestellzeichen order references		Abmessungen dimensions [mm]							Gewicht weight
rechtsgängig right hand	linksgängig left hand	A	D	L	b	c	E	6*S	kg
QFM 12x3 R7	QFM 12x3 L7	48	28	28	12	8	38	6	0,24
QFM 16x2 R7	QFM 16x2 L7	48	28	44	12	8	38	6	0,28
QFM 16x4 R7	QFM 16x4 L7	48	28	44	12	8	38	6	0,28
QFM 16x8P4 R7	---	48	28	44	12	8	38	6	0,28
QFM 18x4 R7	QFM 18x4 L7	48	28	44	12	8	38	6	0,26
QFM 20x2 R7	QFM 20x2 L7	55	32	44	12	8	45	7	0,35
QFM 20x4 R7	QFM 20x4 L7	55	32	44	12	8	45	7	0,35
QFM 20x8P4 R7	---	55	32	44	12	8	45	7	0,35
QFM 20x16P4 R7	---	55	32	44	12	8	45	7	0,35
QFM 22x24P4 R7	---	55	32	44	12	8	45	7	0,40
QFM 24x5 R7	QFM 24x5 L7	55	32	44	12	8	45	7	0,30
QFM 24x10P5 R7	---	55	32	44	12	8	45	7	0,30
QFM 30x4 R7	QFM 30x4 L7	62	38	46	14	8	50	7	0,40
QFM 30x6 R7	QFM 30x6 L7	62	38	46	14	8	50	7	0,42
QFM 30x12P6 R7	---	62	38	46	14	8	50	7	0,42
QFM 32x6 R7	QFM 32x6 L7	62	38	46	14	8	50	7	0,38
QFM 36x6 R7	QFM 36x6 L7	70	45	59	16	10	58	7	0,64
QFM 40x7 R7	QFM 40x7 L7	95	63	73	16	10	78	9	1,82
QFM 50x8 R7	QFM 50x8 L7	110	72	97	18	10	90	11	2,80
QFM 60x9 R7	QFM 60x9 L7	125	85	99	20	10	105	11	3,85



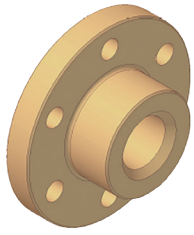

Einbaufertige Rotguss-Flanschmutter - kurz - Typ QFMK
Red Brass Flange Nut finished - short - type QFMK

- Gewinde nach DIN ISO 103
- Werkstoff: CuSn 7Zn (Rg7), (2.1090)
- Thread according to DIN ISO 103
- Material: CuSn (Rg7), (2.1090)

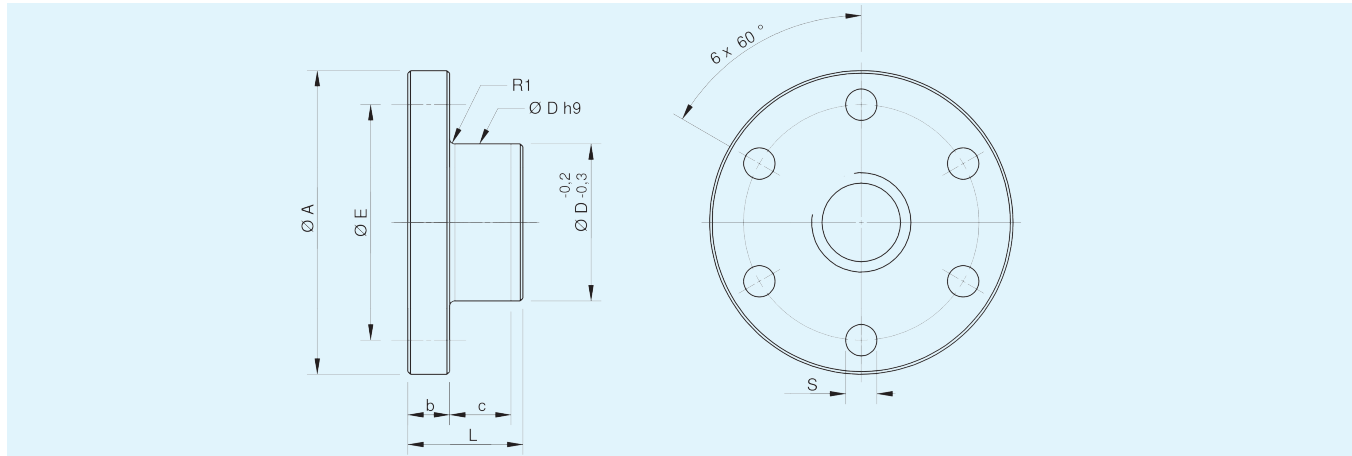

Bestellzeichen order references		Abmessungen dimensions [mm]							Gewicht weight
rechtsgängig right hand	linksgängig left hand	A	D	L	b	c	E	6*S	kg
QFMK 5X1,5 R7	QFMK 5X1,5 L7	20	10	8	3	3	15	2,9	0,01
QFMK 5x3P1,5 R7	---	20	10	8	3	3	15	2,9	0,01
QFMK 8X1,5 R7	QFMK 8X1,5 L7	30	14	13	5	5	22	4,0	0,04
QFMK 10X2 R7	QFMK 10X2 L7	34	16	14	5	6	26	5,0	0,04
QFMK 10x3 R7	QFMK 10x3 L7	34	16	14	5	6	26	5,0	0,04
QFMK 12x2 R7	QFMK 12x2 L7	36	20	16	5	8	28	5,0	0,06
QFMK 12x3 R7	QFMK 12x3 L7	36	20	16	5	8	28	5,0	0,06
QFMK 16x2 R7	QFMK 16x2 L7	48	26	20	7	10	38	6,0	0,14
QFMK 16x4 R7	QFMK 16x4 L7	48	26	20	7	10	38	6,0	0,14
QFMK 18x4 R7	QFMK 18x4 L7	58	30	22	8	12	45	7,0	0,20
QFMK 20x2 R7	QFMK 20x2 L7	58	30	22	8	12	45	7,0	0,20
QFMK 20x4 R7	QFMK 20x4 L7	58	30	22	8	12	45	7,0	0,20
QFMK 20x8P4 R7	---	58	30	22	8	12	45	7,0	0,20
QFMK 24x5 R7	QFMK 24x5 L7	72	40	28	10	12	58	7,0	0,45
QFMK 24x10P5 R7	---	72	40	28	10	12	58	7,0	0,45
QFMK 28x5 R7	QFMK 28x5 L7	78	45	35	10	15	65	7,0	0,59
QFMK 30x4 R7	---	82	50	44	12	15	68	7,0	0,95
QFMK 30x6 R7	QFMK 30x6 L7	82	50	44	12	15	68	7,0	0,95
QFMK 30x12P6 R7	---	82	50	44	12	15	68	7,0	0,95
QFMK 36x6 R7	QFMK 36x6 L7	110	55	55	15	15	85	7,0	1,60
QFMK 40x7 R7	QFMK 40x7 L7	130	60	60	15	20	95	9,0	2,18
QFMK 50x8 R7	QFMK 50x8 L7	160	80	65	15	20	120	11,0	3,68
QFMK 60x9 R7	QFMK 60x9 L7	160	80	65	15	20	120	11,0	3,26



Die QFME ist ein Produkt, das einbaufertig bearbeitet ist. Die Mutter ist zweiteilig und das Spiel kann mittels Verdrehung eingestellt werden.

The QFME is prefinished and can be mounted without further machining. The nut has a two piece design and the backlash can be adjusted by turning relative to each other.

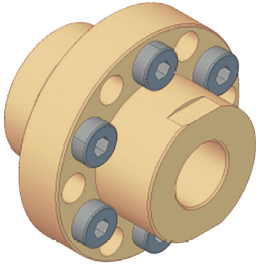

Einstellbare Rotguss-Flanschmutter - Typ QFME
Red Brass Flange Nut adjustable - type QFME

- Gewinde nach DIN ISO 103
- Werkstoff: CuSn 7Zn (Rg7), (2.1090)

- Thread according to DIN ISO 103
- Material: CuSn (Rg7), (2.1090)

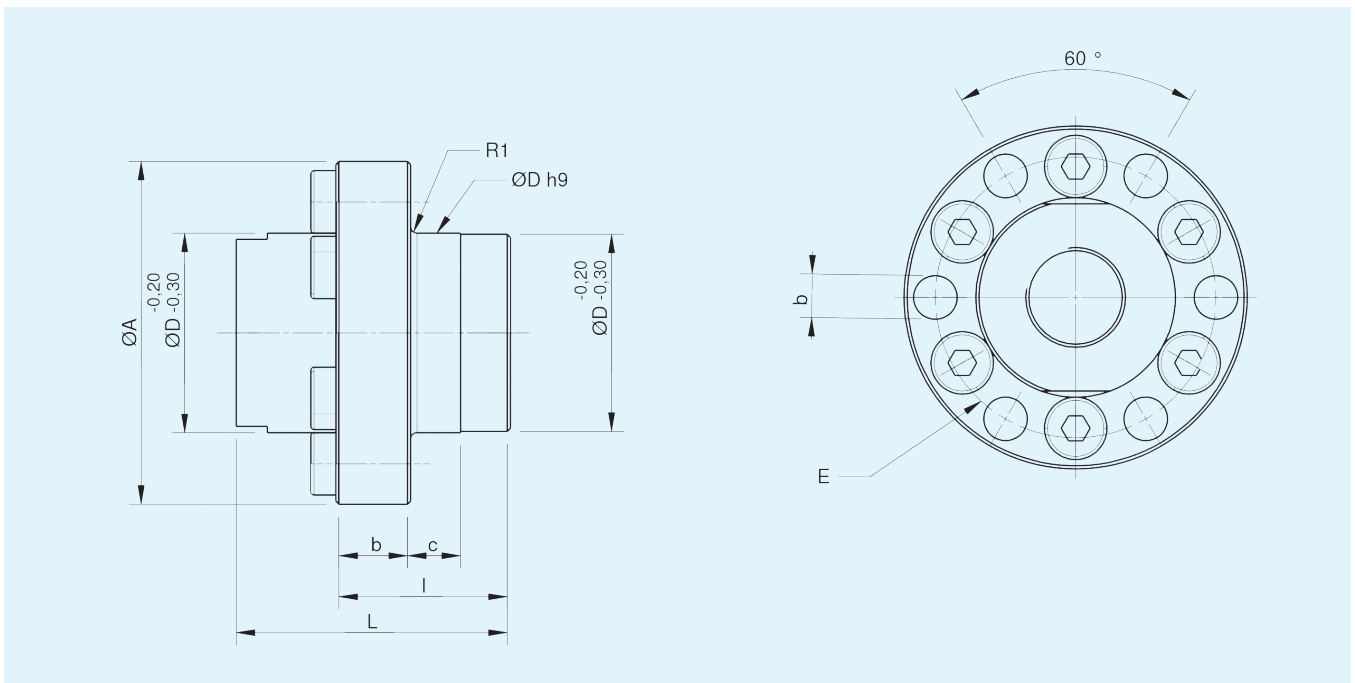

Bestellzeichen order references		Abmessungen dimensions [mm]								Gewicht weight
rechtsgängig right hand	linksgängig left hand	A	D	L	l	b	c	E	6*S	kg
QFME 16x4 R7	QFME 16x4 L7	48	28	44	28	12	8	38	6	0,28
QFME 20x4 R7	QFME 20x4 L7	55	32	44	28	12	8	45	7	0,35
QFME 24x5 R7	QFME 24x5 L7	55	32	44	28	12	8	45	7	0,31
QFME 30x6 R7	QFME 30x6 L7	62	38	46	30	14	8	50	7	0,41
QFMS 36x6 R7	QFME 36x6 L7	70	45	59	37,5	16	10	58	7	0,63
QFME 40x7 R7	QFME 40x7 L7	95	63	73	44,5	16	10	78	9	1,80



Trapezgewindespindeln -Typ QSP Trapezoidal Screws - type QSP

- In Anlehnung DIN 103, 7e
- Werkstoff: 11SMn30, Nummer 1.0715 oder Werkstoff: C15, Nummer 1.0401
- Geradheit 0,3/300 mm
- Lieferlänge: L_{max} ca. 3.000 mm, über 3.000 mm auf Anfrage
- Optional Endenbearbeitung
- According DIN ISO 103, 7e
- Material: 11SMn30, number 1.0715 or material: C15, number 1.401
- Straightness 0,3/300 mm
- max. delivery length: 3.000 mm over 3.000 on request
- End machining on request

Bestellzeichen order references		kleinstmaß Flanken- durchmesser lowest pitch diameter	größtmaß Flanken- durchmesser highest pitch diameter	Kerndurch- messer core diameter	Steigungs- winkel lead angle	Steigungs- genauigkeit lead accuracy	Gewicht weight
rechtsgängig right hand	linksgängig left hand	D1 (mm)	D1 (mm)	D2 (mm)		auf 300 mm per 300 mm	kg/m
QSP 5x1,5 R1	QSP 5x1,5 L1	3,900	3,950	3,30	6°98'	0,1	0,10
QSP 5x3P1,5 R1	---	3,900	3,950	3,30	13°75'	0,2	0,10
QSP 8x1,5 R1	QSP 8x1,5 L1	7,013	7,183	6,10	3°89'	0,1	0,30
QSP 10x2 R1	QSP 10x2 L1	8,739	8,929	6,89	4°2'	0,1	0,50
QSP 10x3 R1	QSP 10x3 L1	8,191	8,415	5,84	6°24'	0,1	0,45
QSP 12x2 R1	QSP 12x2 L1	10,729	10,929	8,89	3°39'	0,1	0,70
QSP 12x3 R1	QSP 12x3 L1	10,191	10,415	7,84	5°11'	0,1	0,70
QSP 12x6P3 R1	---	10,165	10,415	7,84	10°18'	0,2	0,70
QSP 14x3 R1	QSP 14x3 L1	12,191	12,415	9,84	4°22'	0,1	0,95
QSP 14x4 R1	QSP 14x4 L1	11,640	11,905	8,80	6°3'	0,1	0,90
QSP 16x2 R1	QSP 16x2 L1	14,729	14,929	12,89	2°36'	0,1	1,40
QSP 16x4 R1	QSP 16x4 L1	13,640	13,905	10,80	5°11'	0,1	1,20
QSP 16x8P4 R1	---	13,608	13,905	10,80	10°18'	0,2	1,20
QSP 18x4 R1	QSP 18x4 L1	15,640	15,905	12,80	4°32'	0,1	1,60
QSP 20x2 R1	QSP 20x2 L1	18,729	18,929	17,00	1°94'	0,1	1,90
QSP 20x4 R1	QSP 20x4 L1	17,640	17,905	14,80	4°2'	0,1	2,00
QSP 20x8P4 R1	---	17,608	17,905	14,80	8°3'	0,2	2,00
QSP 20x16P4 R1	---	17,608	17,905	14,80	15°47'	0,2	2,00
QSP 22x5 R1	QSP 22x5 L1	19,144	19,394	15,50	4°39'	0,1	2,35
QSP 22x24P4 R1	---	19,140	19,505	16,50	21°34'	0,2	2,35
QSP 24x5 R1	QSP 24x5 L1	21,094	21,394	17,50	4°14'	0,1	2,85
QSP 24x10P5 R1	---	21,058	21,394	17,50	8°25'	0,2	2,85
QSP 26x5 R1	QSP 26x5 L1	23,094	23,394	19,50	3°52'	0,1	3,40
QSP 28x5 R1	QSP 28x5 L1	25,094	25,394	21,50	3°34'	0,1	4,00
QSP 30x4 R1	---	27,640	27,905	25,60	2°62'	0,1	4,80
QSP 30x6 R1	QSP 30x6 L1	25,547	26,882	21,90	4°2'	0,1	4,50
QSP 30x12P6 R1	---	26,507	26,882	21,90	8°3'	0,2	4,50
QSP 32x6 R1	QSP 32x6 L1	28,547	28,882	23,90	3°46'	0,1	5,20
QSP 36x6 R1	QSP 36x6 L1	32,547	32,882	27,90	3°18'	0,1	6,70
QSP 40x7 R1	QSP 40x7 L1	36,020	36,375	31,50	3°29'	0,1	8,20
QSP 40x14P7 R1	---	35,978	36,375	31,50	6°57'	0,2	8,20
QSP 50x8 R1	QSP 50x8 L1	45,468	45,868	39,30	3°10'	0,1	13,10
QSP 60x9 R1	QSP 60x9 L1	54,935	55,360	48,15	2°57'	0,1	19,00



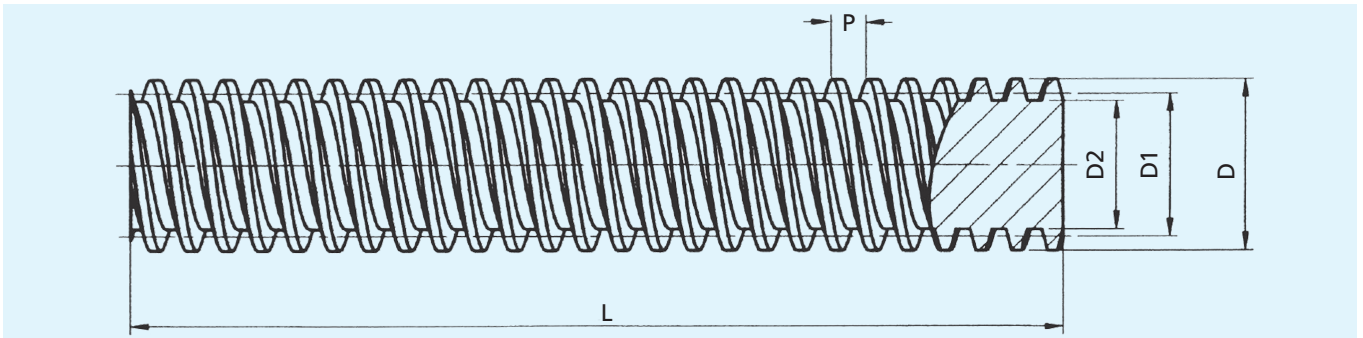

Spindel screw	Loslager floating bearing	Festlager fixed bearing	Flansch-Festlager fixed flange bearing	Kupplung coupling
5x1,5	---	---	---	
5x3P1,5	---	---	---	
8x1,5 *	GAF06SB	GAK06SLB	GFK06SLB	WK14-01R
10x2	GAF06SB	GAK06SLB	GFK06SLB	WK14-01R
10x3*	GAF06SB	GAK06SLB	GFK06SLB	WK14-01R
12x2	GAF06SB	GAK06SLB	GFK06SLB	WK14-01R
12x3	GAF06SB	GAK06SLB	GFK06SLB	WK14-01R
12x6P3	GAF06SB	GAK06SLB	GFK06SLB	WK14-01R
14x3	GAF08SB	GAK08SLB	GFK08SLB	WK20-01R
14x4	GAF08SB	GAK08SLB	GFK08SLB	WK20-01R
16x2	GAF12SB	GAK12SLB	GFK12SLB	WK20-01R
16x4	GAF10SB	GAK10SLB	GFK10SLB	WK20-01R
16x8P4	GAF10SB	GAK10SLB	GFK10SLB	WK20-01R
18x4	GAF12SB	GAK12SLB	GFK12SLB	WK30-01R
20x2	GAF12SB	GAK12SLB	GFK12SLB	WK30-01R
20x4	GAF12SB	GAK12SLB	GFK12SLB	WK30-01R
20x8P4	GAF12SB	GAK12SLB	GFK12SLB	WK30-01R
20x16P4	GAF12SB	GAK12SLB	GFK12SLB	WK30-01R
22x5	GAF12SB	GAK12SLB	GFK12SLB	WK30-01R
22x24P4	GAF12SB	GAK12SLB	GFK12SLB	WK30-01R
24x5	GAF15SB	GAK15SLB	GFK15SLB	WK30-01R
24x10P5	GAF15SB	GAK15SLB	GFK15SLB	WK30-01R
26x5	GAF15SB	GAK15SLB	GFK15SLB	WK40-01R
28x5	GAF20SB	GAK20SLB	GFK20SLB	WK40-01R
30x4	GAF20SB	GAK20SLB	GFK20SLB	WK40-01R
30x6	GAF20SB	GAK20SLB	GFK20SLB	WK40-01R
30x12P6	GAF20SB	GAK20SLB	GFK20SLB	WK40-01R
32x6	GAF20SB	GAK20SLB	GFK20SLB	WK40-01R
36x6	GAF25SB	GAK25SLB	GFK25SLB	WK55-01R
40x7	GBF30SB	GBK30SLB	GFK30SLB	WK65-01R
40x14P7	GBF30SB	GBK30SLB	GFK30SLB	WK65-01R
50x8	GBF35SB	GBK35SLB	GWFF35-B-DF	WK65-01R
60x9	GBF40SB	GBK40SLB	GWFF40-B-DF	WK65-01R

i * evt. Gewinderillen sichtbar / thread grooves may be visible



Unser Service steht Ihnen gerne telefonisch (+41 (0)52 670 06 10) oder per Email (info@tretter.ch) zur Verfügung.
Our Service Department would be delighted to help you either by telephone (+41 (0)52 670 06 10) or e-mail (info@tretter.ch).



Niro-Trapezgewindespindeln - Typ QSP Stainless Trapezoidal Screws - type QSP



rostbeständig
stainless steel

- In Anlehnung DIN 103, 7e
- Werkstoff: V2A, Werkstoffnummer 1.4305 oder 1.4301
- Geradheit 1,0/300 mm
- Lieferlänge: L_{max} ca. 3.000 mm
- Optional Endenbearbeitung
- According DIN ISO 103, 7e
- Material: V2A, number 1.4305 or 1.4301
- Straightness 1,0/300 mm
- max. delivery length: 3.000 mm
- End machining on request

Bestellzeichen order references		kleinstmaß Flanken- durchmesser lowest pitch diameter	größtmaß Flanken- durchmesser highest pitch diameter	Kerndurch- messer core diameter	Steigungs- winkel lead angle	Steigungs- genauigkeit lead accuracy	Gewicht weight
rechtsgängig right hand	linksgängig left hand	D1 (mm)	D1 (mm)	D2 (mm)		auf 300 mm per 300 mm	kg/m
QSP 8x1,5 R5	QSP 8x1,5 L5	7,013	7,183	6,10	3°89'	0,1	0,30
QSP 10x2 R5	QSP 10x2 L5	8,739	8,929	6,89	4°2'	0,1	0,50
QSP 10x3 R5	QSP 10x3 L5	8,191	8,415	5,84	6°24'	0,1	0,45
QSP 12x2 R5	QSP 12x2 L5	10,729	10,929	8,89	3°39'	0,1	0,70
QSP 12x3 R5	QSP 12x3 L5	9,975	10,330	7,84	5°11'	0,1	0,70
QSP 14x3 R5	QSP 14x3 L5	12,190	12,415	9,84	4°22'	0,1	0,95
QSP 16x2 R5	QSP 16x2 L5	14,729	14,929	12,89	2°36'	0,1	1,40
QSP 16x4 R5	QSP 16x4 L5	13,640	13,905	10,80	5°11'	0,1	1,20
QSP 18x4 R5	QSP 18x4 L5	15,640	15,905	12,80	4°32'	0,1	1,60
QSP 20x2 R5	QSP 20x2 L5	18,729	18,929	17,00	1°94'	0,1	1,90
QSP 20x4 R5	QSP 20x4 L5	17,640	17,905	14,80	4°2'	0,1	2,00
QSP 24x5 R5	QSP 24x5 L5	21,094	21,394	17,50	4°14'	0,1	2,85
QSP 26x5 R5	QSP 26x5 L5	23,094	23,394	19,50	3°52'	0,1	3,40
QSP 28x5 R5	QSP 28x5 L5	25,094	25,394	21,50	3°34'	0,1	4,00
QSP 30x6 R5	QSP 30x6 L5	26,547	26,882	21,90	4°2'	0,1	4,50
QSP 32x6 R5	QSP 32x6 L5	28,547	28,882	23,90	3°46'	0,1	5,20
QSP 36x6 R5	QSP 36x6 L5	32,547	32,882	27,90	3°18'	0,1	6,70
QSP 40x7 R5	QSP 40x7 L5	36,020	36,375	31,50	3°29'	0,1	8,20



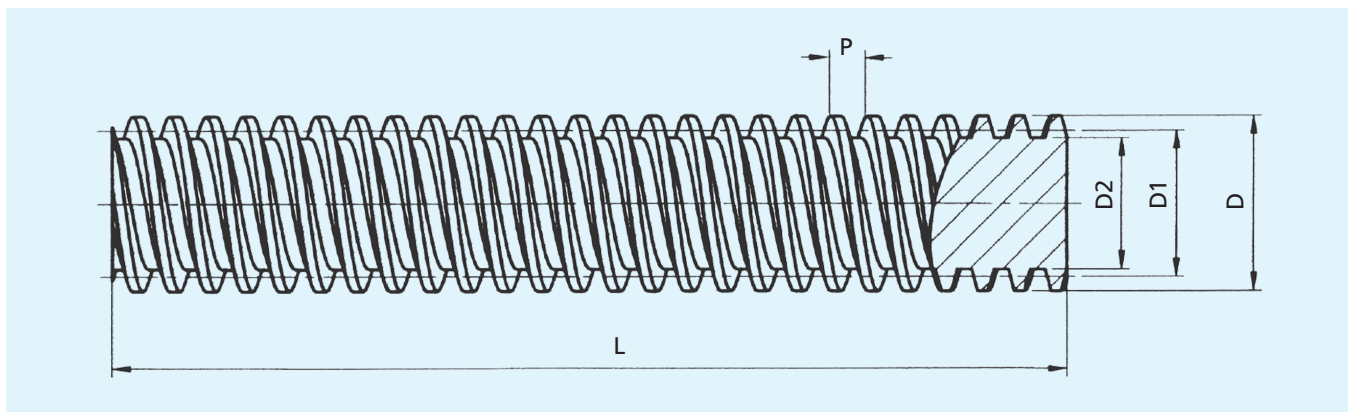

Spindel screw	Loslager floating bearing	Festlager fixed bearing	Flansch-Festlager fixed flange bearing	Kupplung coupling
8x1,5 *	GAF06SB	GAK06SLB	GFK06SLB	WK14-01R
10x2	GAF06SB	GAK06SLB	GFK06SLB	WK14-01R
10x3 *	GAF06SB	GAK06SLB	GFK06SLB	WK14-01R
12x2	GAF06SB	GAK06SLB	GFK06SLB	WK14-01R
12x3	GAF06SB	GAK06SLB	GFK06SLB	WK14-01R
14x3	GAF08SB	GAK08SLB	GFK08SLB	WK20-01R
16x2	GAF12SB	GAK12SLB	GFK12SLB	WK20-01R
16x4	GAF10SB	GAK10SLB	GFK10SLB	WK20-01R
18x4	GAF12SB	GAK12SLB	GFK12SLB	WK30-01R
20x2	GAF12SB	GAK12SLB	GFK12SLB	WK30-01R
20x4	GAF12SB	GAK12SLB	GFK12SLB	WK30-01R
24x5	GAF15SB	GAK15SLB	GFK15SLB	WK30-01R
26x5	GAF15SB	GAK15SLB	GFK15SLB	WK40-01R
28x5	GAF20SB	GAK20SLB	GFK20SLB	WK40-01R
30x6	GAF20SB	GAK20SLB	GFK20SLB	WK40-01R
32x6	GAF20SB	GAK20SLB	GFK20SLB	WK40-01R
36x6	GAF25SB	GAK25SLB	GFK25SLB	WK55-01R
40x7	GBF30SB	GBK30SLB	GFK30SLB	WK65-01R

i * evt. Gewinderillen sichtbar / thread grooves may be visible



Kompetenz hat Tradition.

A history of expertise.

Als persönlicher Entwicklungspartner bieten wir Ihnen:

As a personal development partner, we provide you:

- Fundierte technische Beratung und Projektunterstützung mit langjähriger Erfahrung
- Qualitätsprodukte aus Schweizer Produktion zu einem optimalen Preis-Leistungsverhältnis
- Stete Entwicklung innovativer und ausgereifter Produkte durch ein junges dynamisches Team
- Hohe Lagerverfügbarkeit und schnelle Lieferung unseres breiten Produktesortiments inklusive Niro- & Sonderartikel
- Massgeschneiderte und anwendungsorientierte Lösungen und Bearbeitung von Wellen, Spindeln, Profilschienen etc.

- Sound technical advice and project support based on many years' experience
- Swiss-manufactured quality products at an optimum price/performance ratio
- Constant development of innovative and mature products thanks to a young, dynamic team
- High stock availability and fast delivery of our wide product range, including stainless steel and special items
- Tailored and application-oriented solutions and machining of components such as shafts, spindles and profile rails



Kugelbuchsen & Wellen
Ball bushings & shafts



Drehmomentkugelbuchsen
Ball splines



Schieneführungen
Rail guides



Kugelgewindetriebe
Ball screws



Lineareinheiten
Linear units

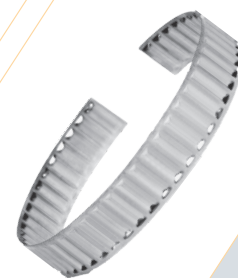

Toleranzhülsen
Tolerance rings



Mehr Informationen (Kataloge, Flyer, Videos und CAD-Daten) finden Sie unter: www.tretter.ch
You will find more information (catalogues, leaflets, videos and CAD data) at: www.tretter.ch



Dr. Tretter AG
Toleranzhülsen
Schaffhauserstr. 96
CH-8222 Beringen

fon +41 52 670 06 10
fax +41 52 670 02 49
mail info@tretter.ch
web www.tretter.ch

Dr. TRETTET AG, © Copyright 2023

Stand/Edition: 01/2023